

1

2

3

4

COMPONENT SPECIFICATION

USE OR REPRODUCTION OF THIS DRAWING FOR THE PURPOSE OF MANUFACTURING THIS ARTICLE OR ANY ARTICLES SHOWN FOR ANY PURPOSE IS STRICTLY PROHIBITED WITHOUT WRITTEN PERMISSION FROM SENIOR INDUSTRIES, INC.

A

B

C

D

E

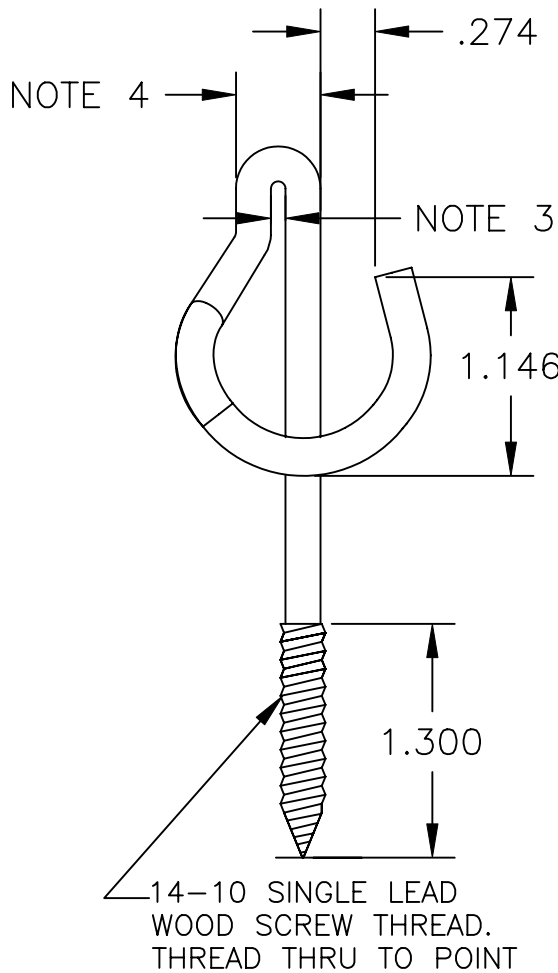
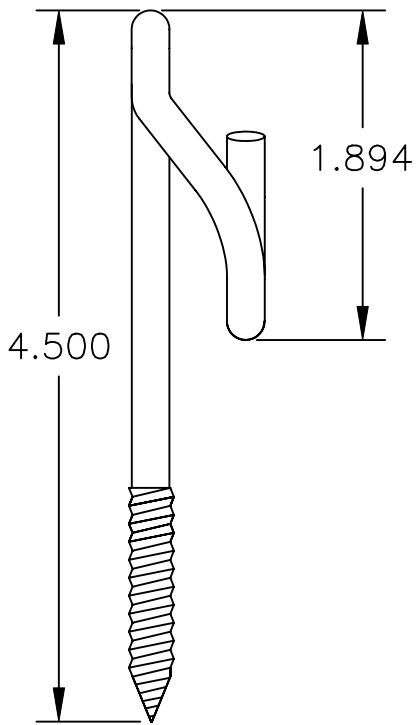
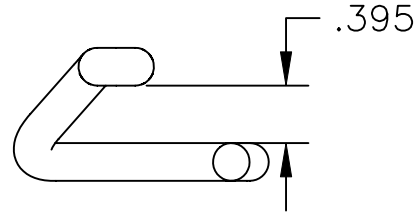

14-10 SINGLE LEAD WOOD SCREW THREAD. THREAD THRU TO POINT

NOTES:

- 1. MATERIAL: MILD STEEL, GALVANIZED PER ASTM A153 OR MECHANICALLY PLATED PER ASTM B695. ROD ϕ .190/.201
- 2. THE HOOK SHALL BE FREE FROM FINIS, FLASHES, CRACKS AND FRACTURES.
- 3. GAP ACCOMMODATES SI-0969 BAIL WIRE.
- 4. NECK FITS SI-7195 TERMINAL WRENCH.

DESIGNED:			SYM.	DATE:	DESCRIPTION OF REVISIONS:	DRAWN	APPD.	
DRAWN:	GAT	06/10/08	Δ	06.10.08	NEW	GAT	JF	
CHECKED:	GAT	02/09/10	Δ	02.09.10	Remv'd stamping & added gap to accom. SI-0969 bail wire	GAT	JF	
APPROVED:	JF	02/09/10	Δ	.	.			
			Δ	.	.			
			Δ	.	.			
3RD ANGLE			UNIT:	IN	SCALE:	1:1	REV.	B



TOLERANCE:		PART NO:
TO 2 DECIMAL PLACE:	\pm	SI-0010CW
TO 3 DECIMAL PLACES:	\pm	TITLE:
AS ANGLES:	\pm °	P HOOK
SHEET:		1 OF 1